

NONLINEAR ANALYSIS OF MULTILAYERED,
HORIZONTALLY, NAIL-LAMINATED WOOD BEAMS

by

D. R. Bohnhoff, Assistant Professor
Agricultural Engineering Department
University of Wisconsin - Madison
Madison, Wisconsin, USA

Written for presentation at the 1988
International Winter Meeting of the
AMERICAN SOCIETY OF AGRICULTURAL ENGINEERS

Hyatt Regency Chicago
in Illinois Center
December 13-16, 1988

SUMMARY:

A simple means to analyze multilayered, horizontally, nail-laminated beams using the direct stiffness method of finite element analysis is presented. Special element stiffness matrices and element load modifying vectors are formulated for use in modeling nail fasteners.

KEYWORDS:

Nails, Modeling, Wood, Beams, Finite Element

This is an original presentation of the author(s) who alone are responsible for its contents.

The Society is not responsible for statements or opinions advanced in reports or expressed at its meetings. Reports are not subject to the formal peer review process by ASAE editorial committees; therefore, are not to be represented as refereed publications.

Reports of presentations made at ASAE meetings are considered to be the property of the Society. Quotation from this work should state that it is from a presentation made by (the authors) at the (listed) ASAE meeting.



**American
Society
of Agricultural
Engineers**

St. Joseph, MI 49085-9659 USA

NONLINEAR ANALYSIS OF MULTILAYERED, HORIZONTALLY NAIL-LAMINATED WOOD BEAMS

by

Dave R. Bohnhoff, Assistant Professor
Agricultural Engineering Department
University of Wisconsin - Madison
Madison, Wisconsin

ABSTRACT

A simple means to analyze multilayered, horizontally, nail-laminated beams using the direct stiffness method of finite element analysis is presented. Special element stiffness matrices and element load modifying vectors are formulated for use in modeling nail fasteners.

INTRODUCTION

Beams which are fabricated by joining individual pieces of wood together fall into four main categories:

1. Horizontally, glue-laminated assemblies.
2. Horizontally, mechanically-laminated assemblies.
3. Vertically, glue-laminated assemblies.
4. Vertically, mechanically-laminated assemblies.

As indicated by the titles of the four preceding groups, laminated assemblies are categorized according to the orientation of the assembly with respect to the applied load, and according to the method used to join the wood pieces together. Briefly, horizontally laminated assemblies are members designed to resist loads applied normal to interlayer planes. Conversely, vertically laminated assemblies are designed to resist loads applied parallel to the planes of contact between layers. Figure 1 illustrates the differences between these two assembly types. Glue-laminated or glulam members are assemblies in which wood layers are rigidly bonded together with an adhesive. In the analysis of these assemblies, it is generally assumed that there is complete composite action, that is, that there is no slip between the layers when the assembly is loaded. Mechanically laminated assemblies - assemblies in which layers are joined together with some type of mechanical fastener (nails, bolts, etc.) - differ from glulam members in that there can be considerable slip between the individual layers.

Almost all glulam assemblies are horizontally laminated. This is primarily due to the fact that all curved beams are horizontally laminated assemblies. It is also important to note that most straight glulam beams are also horizontally laminated. This is primarily due to the fact that in horizontally laminated assemblies, higher grade lumber can be placed farther from the neutral axis and thus is used more effectively. Another advantage of horizontally laminated assemblies is that variations in the modulus of elasticity of individual lamina occur

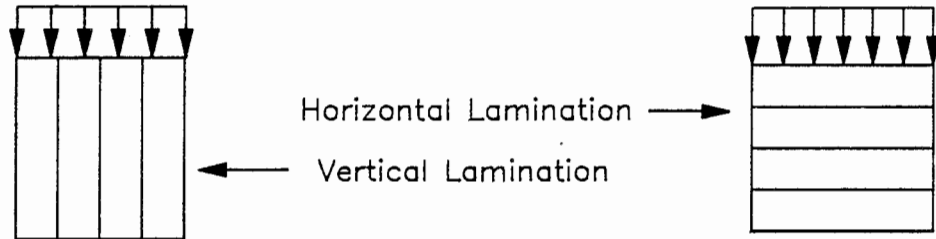

FIG. 1.- Vertical Versus Horizontal Lamination

in a direction parallel to the applied load. Consequently, the shear center of the assembly is not located off to one side of the beam, and therefore, twisting and lateral displacements will be minimal under planar loads. The major disadvantage of horizontally glulam assemblies is that their strength is highly dependent on the quality of the splice joints in the outside laminae.

Mechanical fasteners are generally used when facilities for gluing wood together are not available, or when it is not economical or practical to use glue. Of the different mechanical fasteners available for laminating, nails are far and away the most popular. "Nail-laminated" assemblies find considerable use as girders and columns in residential as well as commercial and industrial buildings.

Unlike for glulams, in nail-laminated assemblies vertical lamination is preferred over horizontal lamination. This is because a measurable amount of interlayer slip must occur before nails transfer any appreciable amount of load. This slip is critical in horizontally laminated assemblies because it can reduce the amount of composite action to the point where individual layers virtually work independently to resist applied loads. Interlayer slip in vertically laminated assemblies is less significant in terms of its effects on overall assembly strength and stiffness. Nails in vertically laminated assemblies basically act as the load distributing elements in a load sharing system.

The significant effect that interlayer slip has on the stiffness of horizontally laminated assemblies has led a number of researchers to develop methods for predicting their behavior. The bulk of this research has involved floor systems fabricated with elastomeric adhesive and nails, and has resulted in the advancement of specialized finite element analysis programs. The first of these programs, FEAFLO, was developed by researchers at Colorado State University (Thompson et al, 1975) and was based on earlier work by Goodman (1969). Other large programs include: NONFLO - an extension of FEAFLO which accounts for nonlinear nail-joint behavior (Wheat et al, 1983), and FAP - a program written by Foschi (1982). A simplified method for computing the deflections of wood-joint floor systems was presented by McCutcheon in 1977 and was based on research by Kuenzi and Wilkinson (1971). McCutcheon (1984) extended his original analysis to account for variable joist stiffness and two-way action. A simple BASIC program for implementing the modified procedure is listed in the 1984 publication.

Other methods for predicting the stiffness of horizontally laminated assemblies with interlayer slip have been developed independently of floor system research. Itani and Hiremath (1980) presented a method of analysis for what they referred to as layered diaphragms. The procedure was implemented in a program called DAD (Difference Analysis of Diaphragms). More recently, Kamiya (1985) formulated a procedure for predicting the nonlinear bending behavior of 2 and 3 layered nail-laminated beams and McCutcheon (1986) developed a simple procedure for computing the linear-elastic composite stiffness of "a wood bending member with sheathing attached nonrigidly to one or both edges."

It is evident from a review of the literature that most of the theoretical analyzes for horizontally laminated assemblies are based on the same assumptions. Therefore, the final governing equations for the theories presented are essentially the same. The analysis methods which currently are available for floor systems can be divided into those which are embodied in finite element programs and those which are not. For the most part, methods which don't involve finite element or finite difference techniques are more limited in terms of their applicability since more restrictions are generally placed on the model in an attempt to simplify the solution process. For example, the analysis may be limited to 2 or 3 layered assemblies, or only certain load configurations or support conditions may apply.

Finite element methods of analysis have increased in popularity due to the advancement of highly reliable and affordable desktop computers. Today, one would be hard pressed to find a structural engineer who is not familiar with the direct stiffness method of structural analysis, or one who does not have access to a simple finite element program for analyzing plane-frame structures. At the same time, it is fair to say that few engineers have ready access to a program for analyzing horizontally nail-laminated assemblies. Unfortunately, what few people realize is that it doesn't take much to turn a conventional program for analyzing plane-frame structures into a program for analyzing horizontally nail-laminated assemblies.

In the following paper, a procedure for analyzing multi-layered, horizontally nail-laminated assemblies using the direct stiffness method of analysis will be presented. Direct physical arguments will be used to formulate the stiffness matrix for both a linear and nonlinear nail element. This type of stiffness matrix formulation is preferred over methods based on the principle of minimum potential energy because it is easier for those with only an introductory background in structural analysis to conceive.

CONSTRUCTION OF THE MODEL

The first step in modeling a multi-layered, horizontally, nail-laminated assembly is to properly divide the beam into elements. This is accomplished by vertically sectioning the beam at any location along the beam where there is: (1) a support, (2) a fastener, (3) an applied load, or (4) a member end. Additional sectionings should be made at any point where displacements are desired. The next step is to place a

node where each section line intersects the neutral axis of a wood layer. If there are n wood layers and s section lines this results in $n*s$ structural nodes. Figure 2(a) shows the location of the section lines for a three layer beam and Figure 2(b) shows the same beam after placement of the nodes.

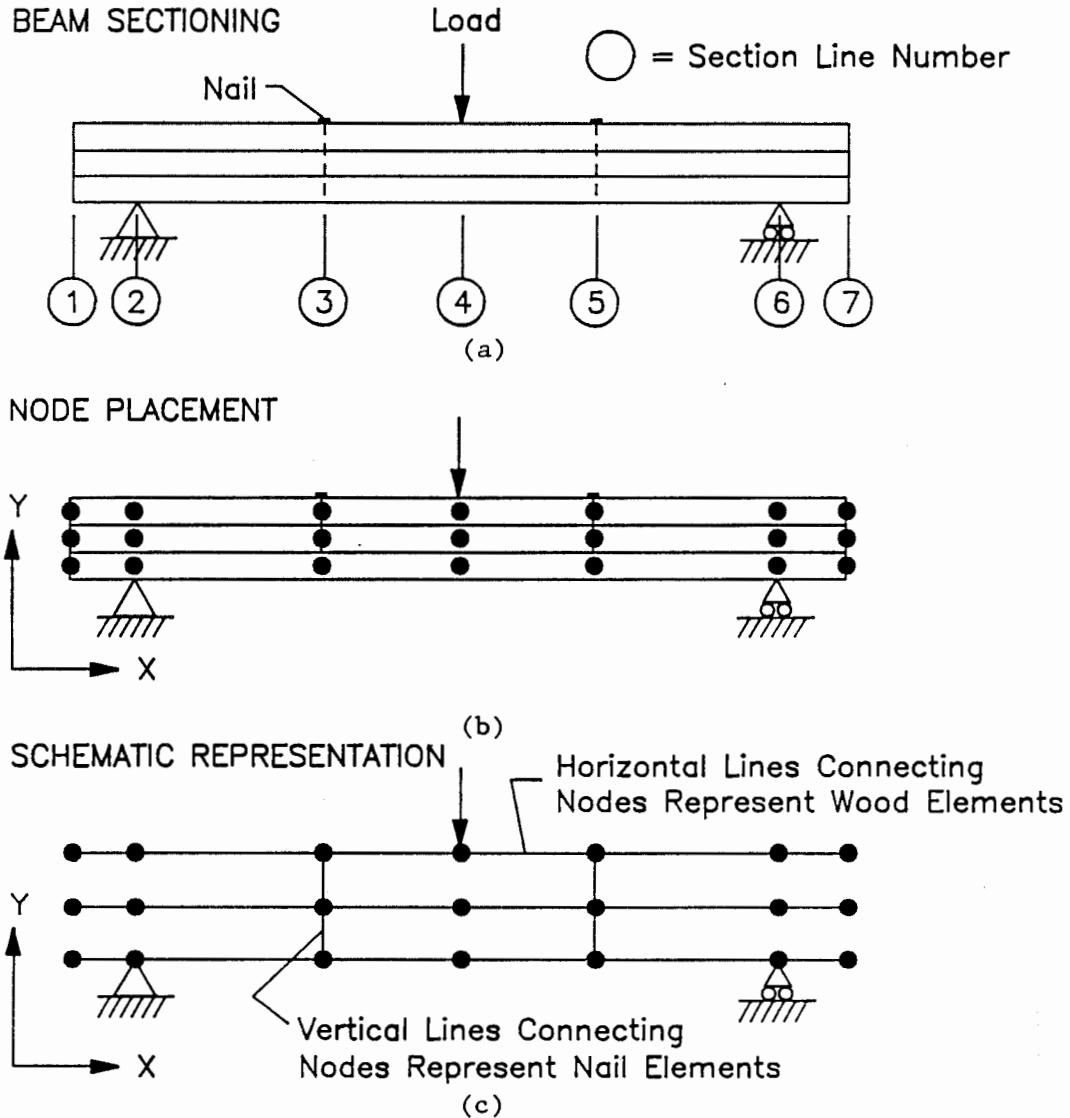

FIG. 2.- Three Layer Assembly. (a) Sectioning. (b) Node Placement. (c) Schematic Representation

BASIC MODELING ELEMENTS

Only two basic elements, a plane-frame wood element and a special nail element, are required to model horizontal, nail-laminated beams. As shown in Figure 2(c), each of these elements is associated with only two structural nodes. The nodes define the ends and neutral axis of the plane-frame wood elements. Since there are usually $s-1$ wood elements per lamina, each model is normally comprised of $n*(s-1)$ wood elements. It is important to note that because section lines were

placed wherever there was a nail, each plane-frame wood element is assured to be void of nails.

Nail elements are used to model nail joints. One nail joint is defined as the connection between two wood layers. A nail in double shear would therefore be modeled using two nail elements. A nail element is associated with the nodes on the section line which lie immediately above and below the nail joint.

INDEPENDENT STRUCTURAL DEGREES OF FREEDOM

Since this is a planar analysis, each node is associated with three degrees of freedom, a vertical (Y) translation, a horizontal (X) translation, and a rotation (about the Z axis). Of the $3*n$ degrees of freedom at a section line, only $n+2$ are independent. This is due to the fact that all nodes which lie on the same section line are forced to have the same Y displacement and consequently, the same Z rotation.

PLANE-FRAME WOOD ELEMENT STIFFNESS MATRIX

In the direct stiffness method of analysis, a stiffness matrix is systematically formulated for each element and added into the structural (or global) stiffness matrix. The stiffness matrix for an element relates the displacements of the element nodes to the forces which must be applied to the nodes to keep the element in a state of static equilibrium. In matrix notation this relationship is written as:

$$[k]\{d\} = \{r\} \quad [1]$$

where:

- [k] = element stiffness matrix.
- {d} = vector of element node displacements.
- {r} = vector of element nodal loads.

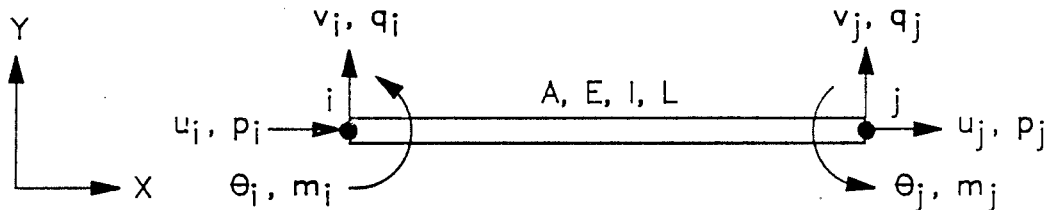

FIG. 3.- Plane-Frame Element

Figure 3 gives the nomenclature and positive sign convention for the nodal forces and displacements acting on the plane-frame element located in layer k between section lines i and j. Since each of the plane-frame wood elements is void of nail joints and assumed to behave linearly-elastically, the relationship between the nodal forces and nodal displacements is given by the conventional plane-frame element stiffness matrix. With respect to the sign convention used in Figure

3, this relationship is given as:

$$\frac{EI}{L^3} \begin{bmatrix} AL^2/I & 0 & 0 & -AL^2/I & 0 & 0 \\ 0 & 12 & 6L & 0 & -12 & 6L \\ 0 & 6L & 4L^2 & 0 & -6L & 2L^2 \\ -AL^2/I & 0 & 0 & AL^2/I & 0 & 0 \\ 0 & -12 & -6L & 0 & 12 & -6L \\ 0 & 6L & 2L^2 & 0 & -6L & 4L^2 \end{bmatrix} \begin{Bmatrix} u_{ik} \\ v_i \\ \theta_i \\ u_{jk} \\ v_j \\ \theta_j \end{Bmatrix} = \begin{Bmatrix} P_{ik} \\ q_i \\ m_i \\ P_{jk} \\ q_j \\ m_j \end{Bmatrix} \quad [2]$$

where

- E - Modulus of elasticity of the wood.
- L - Length of the element or distance between section lines i and j.
- A - Cross-sectional area of the wood element.
- I - Moment of inertia of the wood element about the z axis.
- u_{ik} - Horizontal or X translation of layer k at section line i.
- v_i - Vertical or Y translation of all nodes on section line i.
- θ_i - Rotation of all nodes on section line i.
- u_{jk} - Horizontal or X translation of layer k at section line j.
- v_j - Vertical or Y translation of all nodes on section line j.
- θ_j - Rotation of all nodes on section line j.
- P_{ik} - Horizontal load applied to the element at section line i.
- q_i - Vertical load applied to the element at section line i.
- m_i - Moment applied to the element at section line i.
- P_{jk} - Horizontal load applied to the element at section line j.
- q_j - Vertical load applied to the element at section line j.
- m_j - Moment applied to the element at section line j.

The preceding plane-frame element stiffness matrix has been derived by a number of authors (Wang, 1983; Segerlind, 1984; Cook, 1981; Willems and Lucas, 1978) and will not be formulated here.

FORMULATION OF THE NAIL ELEMENT STIFFNESS MATRIX

Linear Nail-Joint Load-Slip Behavior

Figure 4(a) shows a typical nail joint. The location of the nail at the interface between the top member T and the bottom member B is marked by points C_t and C_b . Both points have the same initial X coordinates, however C_t belongs to member T and C_b belongs to member B. When members T and B slide relative to each other, C_t is displaced from C_b an amount Δ (Figure 4(b)). The quantity Δ is defined as the slip of the nail joint.

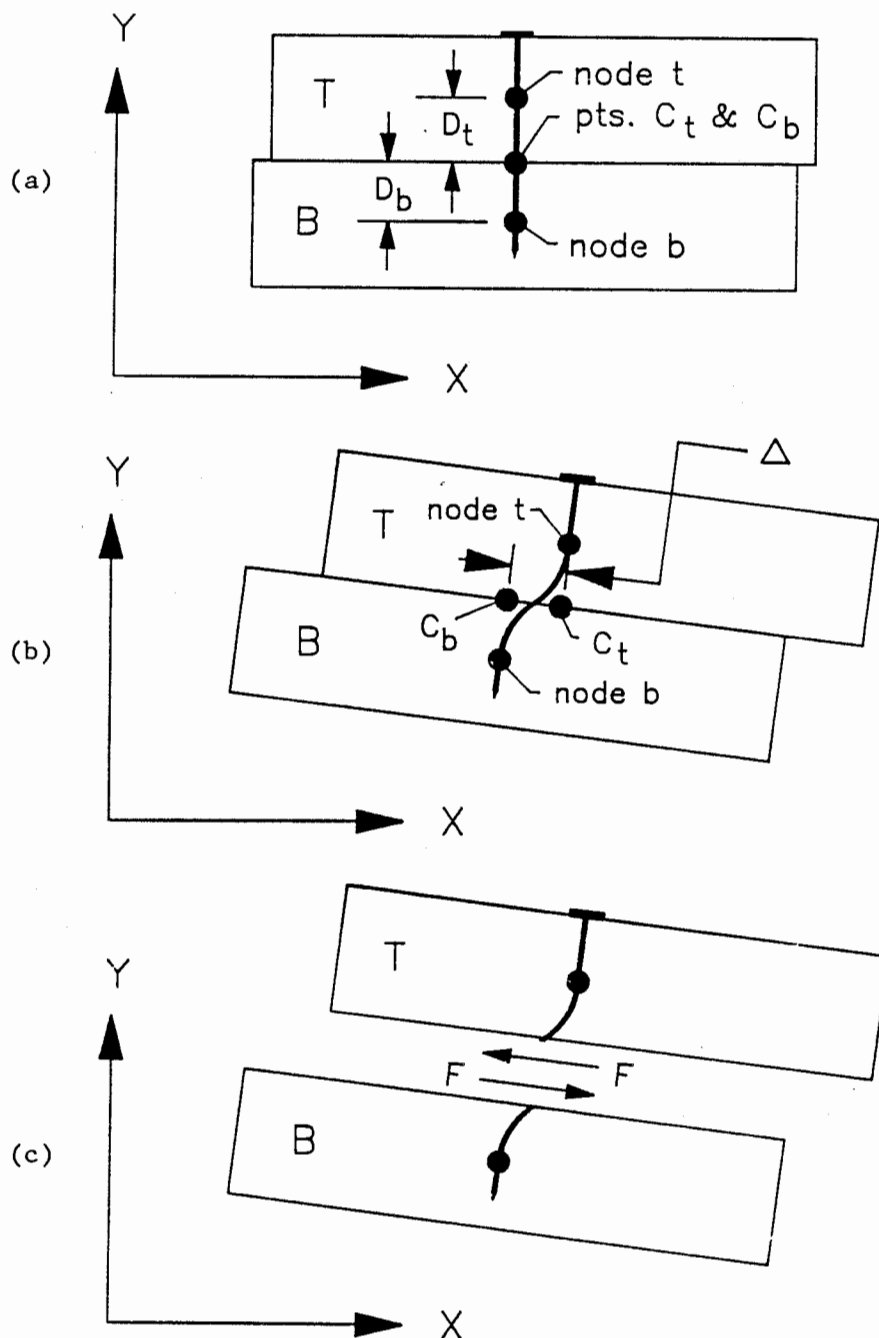

FIG. 4.- Typical Nail Joint. (a) Initial Geometry. (b) Displaced Geometry. (c) Corresponding Nail Shear Force F

As shown in Figure 4(c), the slip Δ of the nail joint induces a resisting shear force F in the nail. The relationship between the force F and the slip Δ is referred to as the nail joint load-slip relationship. This relationship is dependent on the physical and mechanical properties of the nail and the wood as well as the geometry of the joint. It is typically determined by conducting a number of nail joint load-slip tests. A typical nail joint load-slip curve is shown in Figure 5. As the curve indicates, the load-slip relationship of a nail joint is usually highly nonlinear. However, below a certain load limit

(e.g. the fastener design load limit), the load-slip relationship for the joint is often assumed linear and the shear force F is given as:

$$F = k_e * \Delta \quad [3]$$

where k_e is the nail-joint stiffness in the linear-elastic range.

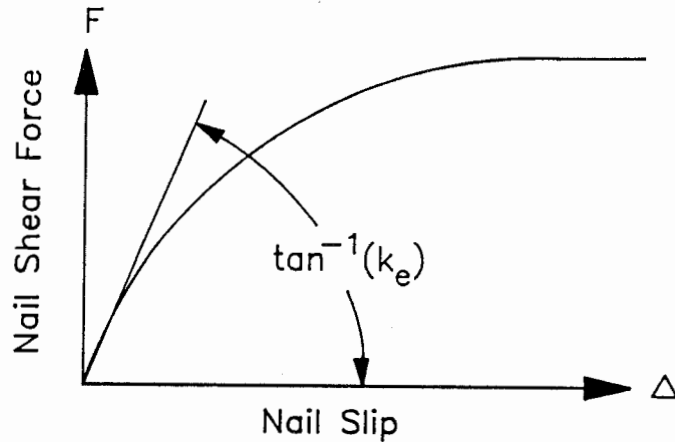

FIG. 5.- Load-Slip Curve for a Typical Nail Joint

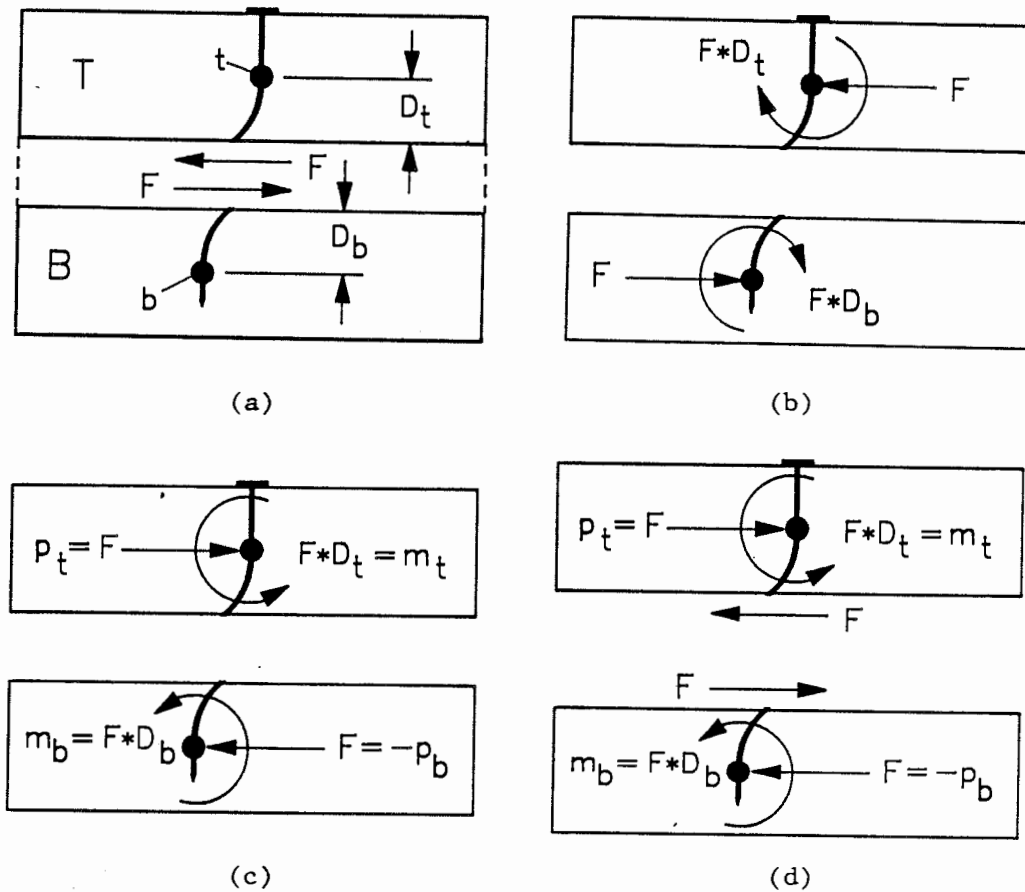

FIG. 6.- (a) Nail Shear Forces. (b) Equivalent Set of Forces Applied to the Element Nodes. (c) Oppositely Acting Forces Required to Maintain Static Equilibrium. (d) Static Force Equilibrium

The nail shear forces F shown in Figure 6(a) can be thought of as externally applied loads and can be replaced by an equivalent set of forces which act at element nodes t and b (Figure 6(b)). To resist these forces and maintain static equilibrium of the "nail element", an equivalent but oppositely acting set of forces must be applied to the nodes (Figure 6(c)). In matrix notation, these forces are given as:

$$\{r\} = \begin{Bmatrix} p_t \\ p_b \\ m \end{Bmatrix} = \begin{Bmatrix} F \\ -F \\ (D_t + D_b) * F \end{Bmatrix} \quad [4]$$

where p_t = Horizontal force applied to node t .
 p_b = Horizontal force applied to node b .
 m = Sum of the moments applied to nodes t and b , positive counterclockwise.
 D_t = Vertical distance between node t and point C_t .
 D_b = Vertical distance between node b and point C_b .

Since the force F is a function of Δ , nodal loads p_t , p_b and m can be related to the displacement of nodes t and b once the relationship between the nodal displacements and the slip Δ is determined. To relate the displacements of nodes t and b to Δ , the X displacements of points C_t and C_b are first defined in terms of the displacements of nodes t and b respectively. That is,

$$u \text{ of } C_t = u_t + D_t * \theta \quad [5]$$

$$u \text{ of } C_b = u_b - D_b * \theta \quad [6]$$

where u = X displacement, positive in the positive X direction.
 u_t = X displacement of node t .
 u_b = X displacement of node b .
 θ = Rotation of all nodes (including t and b) lying on the section line, positive counterclockwise.

In developing the above equations, it is assumed that:

1. Both nodes t and b are located on the neutral axes of their respective members.
2. Node t and point C_t both lie on a line which is perpendicular to the neutral axis of member T , and node b and point C_b both lie on a line which is perpendicular to the neutral axis of member B .
3. The distribution of strains through the depth of the individual layers is linear. Thus, sections of a frame member that are originally plane, remain plane.
4. Rotation θ is small.

Since the slip Δ is equal to the difference between the X displacements of points C_t and C_b , the following equation can be written.

$$\Delta = u_t - u_b + (D_t + D_b) * \theta \quad [7]$$

or in matrix notation,

$$\Delta = [1 \quad -1 \quad D_t + D_b] \{d\} \quad \text{where } \{d\} = \begin{Bmatrix} u_t \\ u_b \\ \theta \end{Bmatrix} \quad [8]$$

In the above equation, Δ is positive if at the interface between the two members, the top member moves in the positive X direction with respect to the bottom member.

$$\{r\} = k_e * \begin{bmatrix} 1 & -1 & (D_t + D_b) \\ -1 & 1 & -(D_t + D_b) \\ (D_t + D_b) & -(D_t + D_b) & (D_t + D_b)^2 \end{bmatrix} \{d\} \quad [9]$$

By definition, the product of k_e and the 3-by-3 matrix is the stiffness matrix for a nail element in which the nail joint exhibits linear load-slip behavior. It is important to realize that with this stiffness matrix and the source code for a conventional plane-frame structural analysis program, a new program can be created for the analysis of any multi-layered, horizontally nail-laminated assembly in which nail joint behavior is assumed linear.

Nonlinear Nail-Joint Load-Slip Behavior

As previously noted, the load-slip relationship of a nail joint is usually highly nonlinear. This nonlinear behavior must be taken into account when the stiffness of a nail-laminated assembly under relatively high loads must be accurately predicted. In equation form, the nonlinear load-slip relationship of a nail joint can be expressed as:

$$F = k(\Delta) * \Delta \quad [10]$$

where $k(\Delta)$ is a secant stiffness that is a function of the slip. When equation [7] is substituted into this load-slip equation and the resulting equation for F is substituted into equation [4], the following element stiffness matrix is obtained:

$$[k(d)] = k(\Delta) * \begin{bmatrix} 1 & -1 & (D_t + D_b) \\ -1 & 1 & -(D_t + D_b) \\ (D_t + D_b) & -(D_t + D_b) & (D_t + D_b)^2 \end{bmatrix} \quad [11]$$

The notation $k(d)$ is used here to indicate that the stiffness matrix is a function of the nodal displacements. This is due to the fact that $k(\Delta)$ from equation [10] is a function of the nodal displacements.

The form that $k(\Delta)$ takes is dependent on the model used to describe the nail joint load-slip relationship. One model that has been used by a number of researchers is the three parameter Foschi equation (Foschi, 1977) which is given as:

$$|F_f| = (\beta_0 + \beta_1 * |\Delta|) [1 - \exp(-\beta_2 * |\Delta| / \beta_0)] \quad [11]$$

where:

- $|F_f|$ = Absolute nail shear force as defined by Foschi equation.
- $|\Delta|$ = Absolute slip.
- β_2 = Initial stiffness.
- β_1 = Stiffness at large slips.
- β_0 = Intercept of the asymptote with slope β_1 .

The plot in Figure 7 of Foschi's equation illustrates the relationship between parameters β_0 , β_1 , and β_2 . Note that when Foschi's equation is used, $k(\Delta)$ in equations [10] and [11] becomes $|F_f|/|\Delta|$.

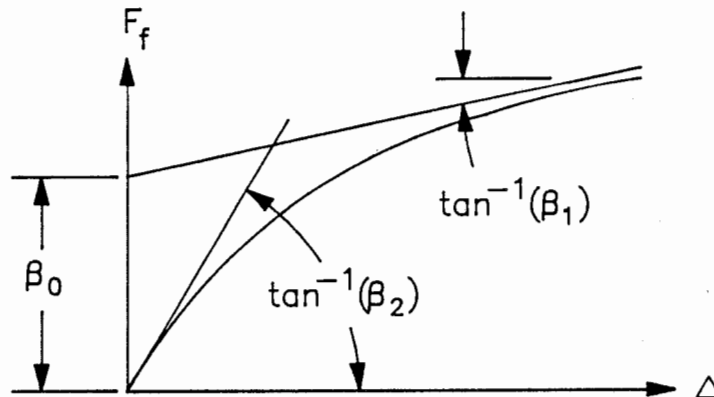

FIG. 7.- Load-Slip Characteristics of the Foschi Equation

Another nonlinear load-slip model which has been used by some researchers is the following two parameter function introduced by McClain (1975).

$$|F_m| = \beta_4 * \log(1 + \beta_5 * |\Delta|) \quad [12]$$

In addition to the McClain and Foschi equations, models consisting of higher order polynomials are commonly fit to load-slip data.

When the element stiffness matrix is a function of nodal displacements the relationship between the loads applied to an element and the nodal displacements is written as:

$$[k(d)](d) = (r) \quad [13]$$

Likewise, the set of structural equilibrium equations has the form:

$$[K(D)](D) = (R) \quad [14]$$

To solve this nonlinear system of equations a technique can be used which involves the removal of all nonlinearities from the element stiffness matrices before the structural stiffness matrix is formulated. The nonlinearities which are removed from an element stiffness matrix show up on the right side of the equation in what is referred to as an element load modifying vector.

The removal of the nonlinearities from the element stiffness matrix is accomplished by adding the term $[k](d)$ to each side of equation [13]

and then rearranging the equation.

$$\begin{aligned} [k]\{d\} &= \{r\} + ([k] - [k(d)])\{d\} \\ [k]\{d\} &= \{r\} + \{w(d)\} \end{aligned} \quad [15]$$

where:

- $\{w(d)\}$ = element load modifying vector,
= $([k] - [k(d)])\{d\}$,
- $[k(d)]$ = actual element stiffness matrix which is a function of nodal displacements,
- $[k]$ = an "approximate" element stiffness matrix. This matrix is not a function of nodal displacements.

As far as the mathematics are concerned, $[k]$ can be any element stiffness matrix that is not dependent on nodal displacements; however, $[k]$ generally represents the initial stiffness of the element or some other linear, first order approximation of the element stiffness. For example, when the Foschi equation (equation [11]) is used to describe the nail joint load-slip characteristics the actual nail element stiffness matrix is given as:

$$[k(d)] = |F_f|/|\Delta| * \begin{bmatrix} 1 & -1 & (D_t + D_b) \\ -1 & 1 & -(D_t + D_b) \\ (D_t + D_b) & -(D_t + D_b) & (D_t + D_b)^2 \end{bmatrix}$$

To obtain an "approximate" element stiffness matrix $[k]$ (one that is not a function of nodal displacements), $|F_f|/|\Delta|$ can be replaced by parameter β_2 - the initial stiffness of the nail joint.

$$[k] = \beta_2 * \begin{bmatrix} 1 & -1 & (D_t + D_b) \\ -1 & 1 & -(D_t + D_b) \\ (D_t + D_b) & -(D_t + D_b) & (D_t + D_b)^2 \end{bmatrix}$$

By definition, the load modifying vector $\{w\}$ then becomes:

$$\{w\} = \begin{Bmatrix} (\beta_2 - |F_f|/|\Delta|) * \Delta \\ (\beta_2 - |F_f|/|\Delta|) * (-\Delta) \\ (\beta_2 - |F_f|/|\Delta|) * (D_t + D_b) * \Delta \end{Bmatrix}$$

where Δ is given by equation [7] and $|F_f|$ by equation [11].

Once assembled, element stiffness matrices and element load modifying vectors are loaded into the global stiffness matrix $[K]$ and global load modifying vector $\{W(D)\}$, respectively. Direct iteration (Cook, 1981) is then used to solve the structural equation system. The system of equations solved by this method has the form,

$$[K]\{D\}_{i+1} = \{R\} + \{W(D_i)\} \quad [16]$$

where:

- $[K]$ = global stiffness matrix.
- $\{R\}$ = load vector.
- $\{W(D_i)\}$ = load modifying vector which is a function of the displacements from the previous iteration.
- $\{D\}_{i+1}$ = vector of unknown displacements.

The global stiffness matrix $[K]$ is formed and reduced only once thereby minimizing computing time. All nonlinearities appear in the load modifying vector $\{W\}$. This vector is calculated using displacements from the previous iteration. The load modifying vector is then added to the load vector and the equation is solved for the unknown displacements $\{D\}_{i+1}$. Initial displacements are found through solution of the linear equation system $[K]\{D\} = \{R\}$.

OVERVIEW

The nodal load-displacement relationships developed in the previous section(s) form the foundation for a finite element program entitled MLBeam that was developed by the author. MLBeam is not an elaborate program. With little work, a program similar to it can be developed by modifying the source code for any plane-frame structural analysis program which incorporates the direct stiffness method of analysis.

Programs based on the method of analysis presented here can be used to analyze a variety of horizontally nail-laminated assembly designs. Basically, there is no limit on the number of layers in the assembly, nor do the layers have to be continuous or complete. The wood members used in an assembly can be of different height, width and MOE. However, they should all be located such that they form a symmetric assembly with respect to the X-Y plane. Note that no limitation need be placed on the location, number, or variety of fasteners used in an assembly. Likewise, no restrictions need be placed on the type, number or location of supports.

If there is a major difference between the method of analysis herein described and those embodied in some of the more sophisticated finite element programs, it is that some of the more elaborate methods of analysis for horizontally laminated assemblies address continuous connections between layers (i.e., elastomeric adhesives). When continuous connections are considered, terms in the structural or global stiffness matrix become more complex. There are also more nonzero off-diagonal terms in the matrix. This is due to the fact that nodal displacements in the Y direction are not always uncoupled from nodal forces which act in the X direction. The fact that some nodal Y displacements will be related to X directed nodal forces is illustrated in Figure 8. When both nodes on the same end are given a Y displacement (with all other nodal displacement degree of freedoms fixed) there is a certain amount of interlayer slip (although none actually occurs right at the member ends). If adhesive is used which

resists this slip, X directed forces will have to be applied to the nodes to maintain static equilibrium of the free body.

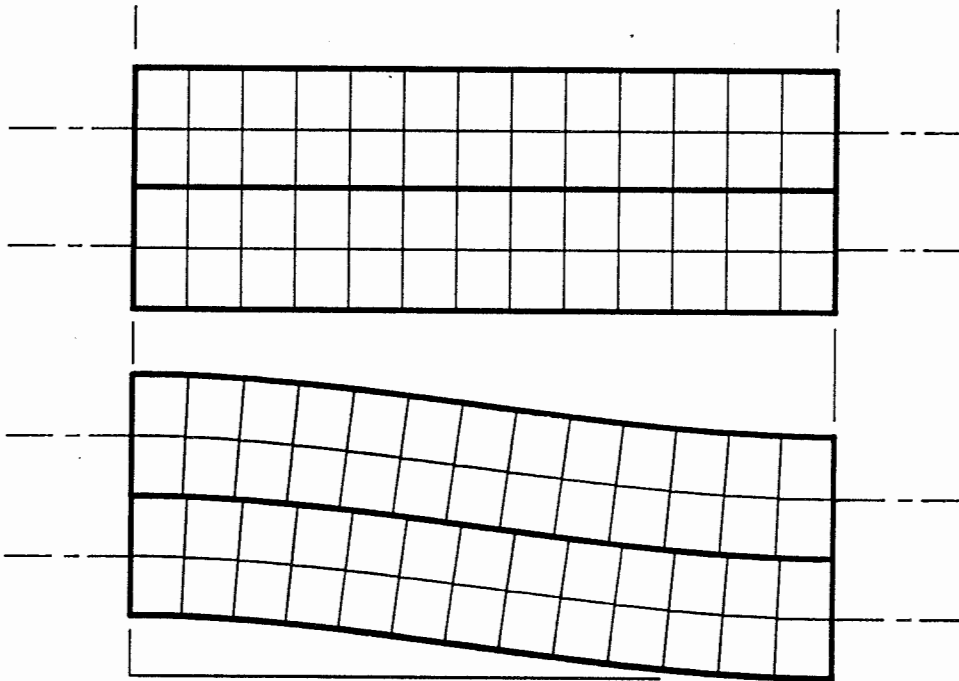

FIG. 8.- Interlayer Slip Caused By A Vertical Translation of the Left Element Nodes

Programs like MLBeam can be used to approximate the stiffness of assemblies with elastomeric adhesive. This is accomplished by using a series of nail elements and assigning each element a stiffness equivalent to that which the adhesive has over an area defined by the nail element spacing.

SUMMARY

A nonlinear, two-dimensional, finite element program was developed for analyzing multilayered, horizontally nail-laminated beams. Nodal load-displacement relationships were formulated for a special nail element using direct physical arguments. The nail element is used to model nail shear joints between layers. It is the only element in addition to the conventional plane-frame element that is needed to model horizontally nail-laminated assemblies.

REFERENCES

- Cook, R. D. 1981. Concepts and Applications of Finite Element Analysis. 2nd Edition, John Wiley and Sons, Inc. New York, New York.

- Foschi, R. O. 1977. "Analysis of Wood Diaphragms and Trusses. Part I: Diaphragms." Canadian Journal of Civil Engineering, 4(3):345-352.
- Foschi, R. O. 1982. "Structural Analysis of Wood Floor Systems." Journal of the Structural Division, ASCE, 108(ST7):1557-1574.
- Goodman, J. R. 1969. "Layered Wood Systems with Interlayer Slip." Wood Science, 1(3):148-158.
- Itani, R. J. and Hiremath, G. S. 1980. "Partial Composite Action in Diaphragms." Journal of the Engineering Mechanics Division, ASCE, 106(EM4):739-752.
- Kamiya, Fumio 1985. "Nonlinear Bending Behavior of Nailed Layered Beams." Wood and Fiber Science, 17(1):117-131.
- Kuenzi, E. W. and Wilkinson, T. L. 1971. Composite Beams-Effect of Adhesive or Fastener Rigidity. USDA Forest Service Research Paper FPL152. Forest Products Laboratory, Madison, WI.
- McClain, T. E. 1975. Curvilinear Load-Slip Relationships in Laterally Loaded Nailed Joints. PhD Thesis. Colorado State University, Fort Collins, CO.
- McCutcheon, W. J. 1977. Method for Predicting the Stiffness of Wood-Joist Floor Systems with Partial Composite Action. USDA Forest Service Research Paper FPL289. Forest Products Laboratory, Madison, WI.
- McCutcheon, W. J. 1984. Deflections of Uniformly Loaded Floors: A Beam-Spring Analog. USDA Forest Service Research Paper FPL449. Forest Products Laboratory, Madison, WI.
- McCutcheon, W. J. 1986. "Stiffness of Framing Members With Partial Composite Action" Journal of the Structural Division, ASCE, 112(ST7):1623-1637.
- Seegerlind, L. J. 1984. Applied Finite Element Analysis. 2nd Ed., John Wiley and Sons, Inc. New York, New York.
- Thompson, E. G., Goodman, J. R., and Vanderbilt, M. D. 1975. "Finite Element Analysis of Layered Wood Systems." Journal of the Structural Division, ASCE, 101(ST12):2659-2672.
- Wang, C. K. 1983. Intermediate Structural Analysis. McGraw-Hill Book Company, New York, New York.
- Wheat, D. L., Vanderbilt, M. D., and Goodman, J. R. 1983. "Wood Floors With Nonlinear Nail Stiffness." Journal of Structural Engineering, ASCE, 109(5):1290-1302.
- Willems, W. and Lucas, W. M. 1978. Structural Analysis for Engineers. McGraw-Hill Company Inc., New York, New York.